

BLIZZARD® **POWER PLOW**



*2005 Assembly & Operation Manual
Models: 810SS & 8611SS*

INTRODUCTIONS/TABLE OF CONTENTS

Congratulations on purchasing the most advanced, all-season skid steer snowplow available! The Blizzard Power Plow® snowplow is clearing new trails for innovative design, rugged durability, quality craftsmanship and superior performance. Our exclusive products are manufactured and tested in Michigan's Upper Peninsula, the snow capital of the Midwest. With an annual snowfall averaging over 250" we couldn't imagine building snow removal products anywhere else!

TABLE OF CONTENTS

Safety	3
Operation	4
Unpacking & Inspection	5
Technical Specifications	6
Torque Specifications	7
Moldboard Assembly	8
A-Frame Assembly	9
Electrical Assembly.....	12
Mounting & Dismounting Instructions	19
Testing your Plow	20
Maintenance	21
Troubleshooting	22
Moldboard & Wing Parts.....	24
A-Frame, Pivot Beam & Manifold Parts.....	26
Harnesses, Accessories & Kits.....	28
Warranty	30

**WARNING**

Prior to operating your Power Plow® snowplow, review the WARNING! label at the passenger's side rear of the moldboard (shown below).

**CAUTION**

NOTE: Read and understand all warnings indicated in this manual prior to operating the snowplow. Warnings and cautions in the manual are indicated by the icons shown at left.

NOTE: If at any time the safety labels become illegible, promptly replace them.



WARNING

1. Properly mount the snowplow attachment prior to moving the skid steer.
2. Always inform persons to stand clear of the snowplow and skid steer attachment plates when mounting. Failure to do so may result in serious injury or death.
3. Securely position all mounting levers prior to operating your skid steer attachment.
4. Never use the snowplow attachment to carry people, as a man lift or work platform.
5. Always travel with the wings fully retracted.
6. Do not change the position of the blade while in transit.
7. Always lower the attachment when the skid steer is parked.
8. Never stand, work or reach under lift arms or lift cylinders without an approved lift arm stop installed. Failure to do so may result in serious injury or death.
9. Use caution when plowing with down pressure. The plow attachment can cause the front wheels on the skid steer to raise.

**WARNING**

10. High pressure hydraulic fluid can puncture skin causing serious injury or death. In the event of a hydraulic leak, lower load or relieve hydraulic pressure before loosening hydraulic fittings.

If injured, seek emergency medical help immediately.



**READ
OWNER'S
MANUAL
THOROUGHLY
PRIOR TO
OPERATING
PLOW.**



Calumet, MI 49913

BLZ 1013

OPERATION

Your Blizzard Power Plow® snowplow is the most advanced and versatile snowplow on the market. The easy-to-use controls allow you to automatically adjust the plow blade and wings into an infinite number of plowing positions. Review the illustrations below to determine the best position for your plowing needs.

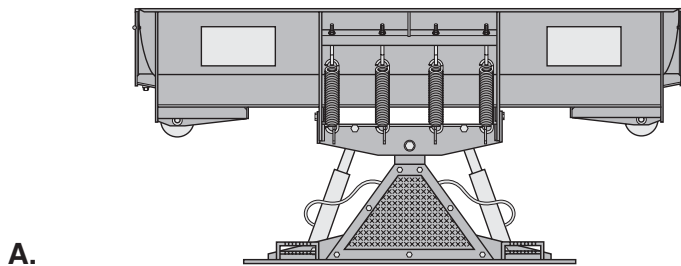

A. Compact Position

(8' or 8'-6" Blade Width)

- Primary position when transporting the snowplow
- For use in heavy snow conditions with poor visibility, initial clearing and tight quarters
- *Ideal application: Residential driveways, small roads*

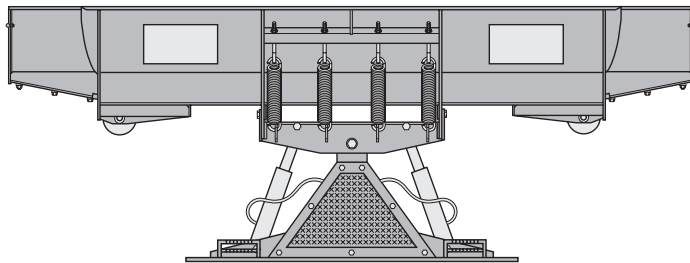

B. WidePass™ Position

(10' or 11'-3" Blade Width)

- Primary position for clearing large surfaces
- For use in light snow conditions with good visibility, final clearing and clean-up
- *Ideal application: Large parking lots, widening roadways*

C. BucketBlade™ Position

(9'-3" or 9'-10" Blade Width)

- Primary position for transporting snow
- For use in initial clearing with decent visibility, transporting large volumes of snow, final clean-up
- *Ideal application: Roadway intersections*

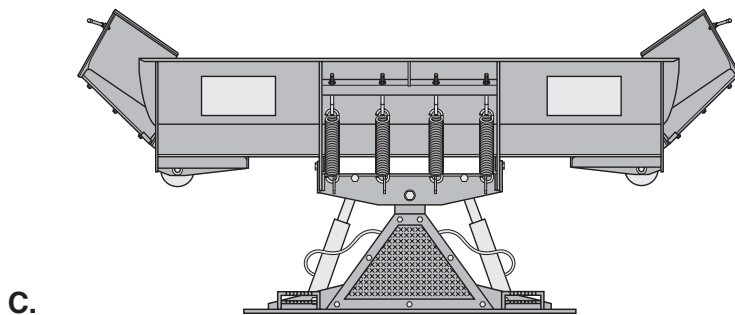

D. WidePass™ Position Angled with Wing Forward

- Primary position for accelerated angled plowing
- For use in directional plowing, cornering, diverting snow away from objects or buildings
- *Ideal application: Plowing adjacent to buildings, driveway /road intersections*

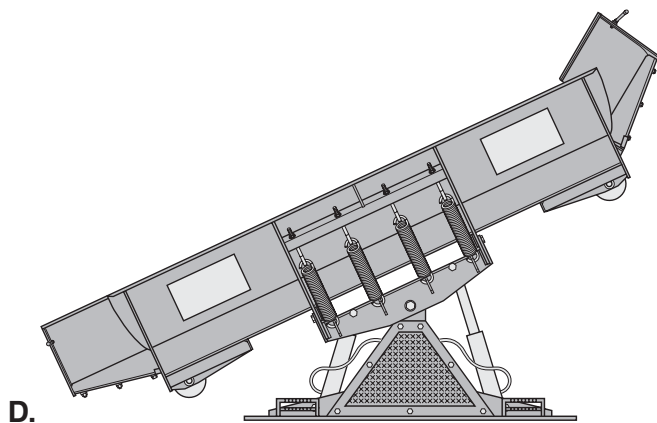

Your Blizzard Power Plow® snowplow has been packaged to withstand transit and weather related damage. Fully inspect all components upon receipt of your plow. In the event of shipping damage or missing parts, immediately contact our Customer Service Department at 1-888-680-8600.

Begin unpacking and inspection in the following order:

1. Remove the shipping document from the end panel of the pallet wrap. Retain all documentation for your records.
2. All wood framing and polyethylene material should be removed from the pallet for easy access to the snowplow.
3. Due to the odd shaped components and size of several assembly parts, various cable ties and corrugated material are used for scratch resistance and package orientation. Please remove these items prior to assembly.
4. Place the main blade assembly on a flat, level surface.

Once you have inspected all parts and removed all packaging materials, your snowplow is ready to be fully assembled.

Retain this information for your records.

_____ DATE OF PURCHASE:
_____ DEALER/DISTRIBUTOR:
_____ DEALER PHONE NUMBER:
_____ SNOWPLOW SERIAL NUMBER:
_____ HYDRAULIC PUMP SERIAL NUMBER:



Pallet Wrap End Panel

The tear-resistant, woven polyethylene pallet wrap contains a moisture barrier to help protect all packaged components and keep out the most inclement weather during shipping and storage. The end panel of the pallet cover contains important information regarding the snowplow model and the plow's serial number. Both of these numbers are given together. The first three (four) digits of the number indicated is always the plow model – 810 (or 8611) and the entire number is the serial number (Ex: 810-00001 or 8611-00001). The shipping document is also attached to the end panel. Be sure to retain this list for your records.

TECHNICAL SPECIFICATIONS

PART	SPECIFICATION	810	8611
MOLDBOARD	Length	96" (8')	102" (8'6")
	Thickness	12 gauge	11 gauge
	Height	31"	34"
	Reinforcement	4 ribs @ 1/4"	
	Cutting Edge	1/2" x 6"	5/8" x 6"
	Finish	Powder Coat White	
	Trip Mechanism	(4) 3/8" hooked extension	(6) 3/8" hooked extension
WINGS	Length	12"	23"
	Thickness	11 gauge	7 gauge
	Height	31"	34"
	Reinforcement	1 rib @ 1/4"	
	Cutting Edge	1/4" X 10" T1	3/8" X 12-1/2" T1
A-FRAME	Finish	Powder Coat White	
	Material	1/4" & 5/16" Mild Steel	
	Cover	1/4" Mild Steel w/ non-skid texture	
MANIFOLD	Finish	Powder Coat Black	
	Construction	Clear Anodized Aluminum	Gold Anodized Aluminum
	Valves	Electro-hydraulic cartridge	

PART	SPECIFICATION	810	8611
CYLINDERS	<i>Angle Cylinders</i>	2	
	Stroke	10"	
	Ram Diameter	1-3/4"	2"
	Bore Diameter	2"	2-1/4"
	<i>Slide Box Cylinders</i>	2	
	Stroke	13-15/16"	18-7/16"
	Ram Diameter	1"	1-1/8"
	Bore Diameter	1-1/2"	1-3/4"
	PLOW SPECS.	Weight*	950 lbs.
Compact Width		96" (8')	102" (8'-6")
WidePass™ Width		120" (10')	132" (11'-3")
BucketBlade™ Width		111"(9'-3")	118"(9'-10")
Adjustable Plow Shoes		(2) Heavy-Duty Cast Steel	
Mount Mechanism		Universal Attachment Plate	
Standard Control Station		Pistol Grip w/ 3 switches	
Integrated Control (Optional)		Auxiliary Harness w/ Diodes	
Anti-Trip Mechanism (Optional)		One-Piece Trip-Lock bar	

Blizzard Corporation reserves the right, under its Continuous Improvement Policy, to change construction or design details and furnish equipment when so altered without reference to illustrations or specifications.

TORQUE SPECIFICATIONS



Grade Identification Marking for J429-Grade 5 Bolt

Nominal Thread Size	SAE J429 – Grade 5		
	Clamp Loads (lbs)	Tightening Torque	
		“Lubricated”	“Dry”
1/4-20	2,000	6 ft-lbs	8 ft-lbs
5/16-18	3,350	13 ft-lbs	18 ft-lbs
3/8-16	4,950	23 ft-lbs	31 ft-lbs
7/16-14	6,800	37 ft-lbs	50 ft-lbs
1/2-13	9,050	57 ft-lbs	75 ft-lbs
9/16-12	11,600	82 ft-lbs	109 ft-lbs
5/8-11	14,500	113 ft-lbs	151 ft-lbs
3/4-10	21,300	200 ft-lbs	266 ft-lbs
7/8-9	29,435	321 ft-lbs	430 ft-lbs
1-8	38,600	482 ft-lbs	640 ft-lbs



Grade Identification Marking for J429-Grade 8 Bolt

Nominal Thread Size	SAE J429 – Grade 8		
	Clamp Loads (lbs)	Tightening Torque	
		“Lubricated”	“Dry”
1/4-20	2,850	9 ft-lbs	12 ft-lbs
5/16-18	4,700	18 ft-lbs	25 ft-lbs
3/8-16	6,950	32 ft-lbs	44 ft-lbs
7/16-14	9,600	53 ft-lbs	70 ft-lbs
1/2-13	12,800	80 ft-lbs	107 ft-lbs
9/16-12	16,400	115 ft-lbs	154 ft-lbs
5/8-11	20,300	159 ft-lbs	211 ft-lbs
3/4-10	30,100	282 ft-lbs	376 ft-lbs
7/8-9	41,550	454 ft-lbs	606 ft-lbs
1-8	54,540	680 ft-lbs	900 ft-lbs



Grade Identification Marking for Metric-Grade 8.8 Bolt

Diameter (mm)	Metric Class 8.8		
	Clamp Loads (Pounds)	Tightening Torque	
		“Lubricated”	“Dry”
5	1,389	3 ft-lbs	5 ft-lbs
6	1,965	6 ft-lbs	8 ft-lbs
7	2,826	10 ft-lbs	13 ft-lbs
8	3,579	14 ft-lbs	19 ft-lbs
10	5,672	28 ft-lbs	37 ft-lbs
12	8,243	49 ft-lbs	65 ft-lbs
14	11,246	77 ft-lbs	103 ft-lbs
16	15,882	125 ft-lbs	167 ft-lbs
18	19,423	172 ft-lbs	229 ft-lbs
20	24,784	244 ft-lbs	325 ft-lbs



Grade Identification Marking for Metric-Grade 10.9 Bolt

Diameter (mm)	Metric Class 10.9		
	Clamp Loads (Pounds)	Tightening Torque	
		“Lubricated”	“Dry”
5	1,987	5 ft-lbs	7 ft-lbs
6	2,812	8 ft-lbs	11 ft-lbs
7	4,044	14 ft-lbs	19 ft-lbs
8	5,121	20 ft-lbs	27 ft-lbs
10	8,116	40 ft-lbs	53 ft-lbs
12	11,796	70 ft-lbs	92 ft-lbs
14	16,092	111 ft-lbs	148 ft-lbs
16	21,970	173 ft-lbs	231 ft-lbs
18	26,868	238 ft-lbs	317 ft-lbs
20	34,284	338 ft-lbs	450 ft-lbs

37° JIC Flare Torque Values

Turns	Size	Ft-lbs min.max	Assembly steps
N/A	-02	6-7	<ol style="list-style-type: none"> 1. Make sure the tubing and threads are clean. 2. Lubricate the threads with 10W hydraulic oil. 3. Hand tighten the nut/sleeve to approx. 30 in-lbs. 4. Make alignment marks on the nut and fitting. 5. Tighten to turn or torque specification. 6. When fully tightened, make a 2nd set of alignment marks at the fully tighten positioned.
N/A	-03	8-9	
2	-04	11-12	
2	-05	14-15	
1-1/2	-06	18-20	
1-1/2	-08	36-39	
1-1/2	-10	57-63	<p>NOTE: Torque values specified are for threads lubricated with 10W hydraulic oil.</p> <p>Over tightening will reduce the clamping force resulting in loss of seal and reduction of flow.</p>
1-1/4	-12	79-88	
1	-14	94-103	
1	-16	108-113	
1	-20	127-133	
1	-24	158-167	
1	-32	245-258	

O-Ring Boss Torque Values

Size	Ft-lbs min.max	Assembly steps
-02	6-7	<ol style="list-style-type: none"> 1. Verify the port, o-ring, sealing surfaces and threads are clean and free of damage. 2. Lubricate the threads and the o-ring with 10W hydraulic oil. 3. For an adjustable O.R.B., completely back off the lock nut and washer. 4. Hand tighten the fitting until it contacts the port spotface. Point the elbow or tee in the desired direction and hold. 5. Torque to specification.
-03	8-10	
-04	13-15	
-05	17-21	
-06	22-25	
-08	40-43	<p>NOTE: Torque values specified are for threads lubricated with 10W hydraulic oil.</p>
-10	43-57	
-12	68-75	
-14	90-99	
-16	112-123	
-20	146-200	
-24	154-215	
-32	218-290	

MOLDBOARD ASSEMBLY

1. Remove dust cap from both of the slide box cylinders located at the center/rear of the moldboard. Attach adapters (**60007** on the 810SS and **60272** on the 8611SS) to each of the base ports and rod ports.

NOTE: All of the hydraulic adapters can be found packaged with the manifold assembly.

2. Connect hoses (**60224**) to each of the hydraulic adapters on the cylinders. *NOTE: Review the label on each hose for the appropriate part number*
3. Position the pivot beam and A-frame, near the mount locations at the rear of the blade. Place the slide box cylinder hydraulic hoses through the rubber grommet openings on each side of the front face of the pivot beam.
4. Position the pivot beam between the two support ribs until the connecting points on the beam align with those on the plow. Insert clevis pin (**50069**) through each mounting hole and secure with cotter pins (**61357**).
5. Hook each extension spring to the receiving holes on the pivot beam and attach the opposite end of the spring to its respective spade bolts. Install the spade bolts through the extension spring mounting angle on the top rear of the blade. Secure spade bolts with a 5/8" flat washer and a 5/8"-11 nylock nut. Tighten each nut until a piece of paper can pass between the 3rd & 4th coils on the spring.
6. Install the blade guides at each end of the moldboard. Insert the capscrew through the holes at the top of the wing reinforcement rib. Tighten all screws with lock nuts.
7. Assemble the A-Frame.

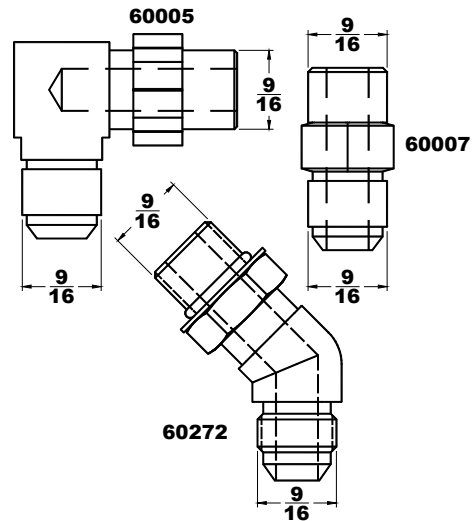

Skid Steer Adapters

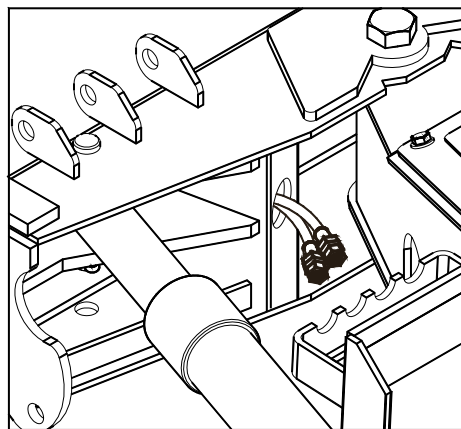

Feed each group of hoses, 2 per side, through the grommets in the pivot beam. Positioning the hoses through the pivot beam supports the hoses while in use and prevents them from dragging on the ground.

A-FRAME ASSEMBLY

1. The manifold and angle cylinders have been secured to the A-Frame at the factory; however, each contains several components that you will need to install.
2. Remove the A-Frame cover to gain access to the manifold.
3. Each of the hose ports on the manifold are covered with stretch wrap. Remove the wrap and install adapter (**60272**) to ports #1, 2, 7, 8, 9 & 10.

NOTE: DO NOT let any foreign objects enter into the open ports. The valves can become contaminated and greatly hinder the plow's performance. Torque to proper specifications.

NOTE: All ports are identified by a stamped number on the manifold. The numbers also identify the hydraulic functions, which can be referenced on the label under the manifold cover.

4. Route the hydraulic hose groupings from the pivot beam to the access holes located on the sides of the a-frame. Connect the hoses to their respective adapters on the manifold.



CAUTION: When handling the manifold, hold the manifold at the sides of the block. Never handle the manifold by coils. Doing so can cause a solenoid cartridge to bend, causing the cartridge to stick when activated.

5. Remove the dust cap from both of the hydraulic angle cylinder ports and attach a 90° adjustable elbow adapter (**60005**) to each port. Each adapter should be angled toward the top of the moldboard. Connect one 3/8" x 26" (**60223** or **60224** 36" for 8611) hydraulic hose to each angle cylinder adapter. Be careful not to over tighten the hose connections. **NOTE:** The cylinder ports should be facing away from the A-frame. **NOTE:** The 810SS & 8611SS A-frame are the same but use different mounting points for the angle cylinders due to different stroke length on the cylinders. Use caution when replacing.
6. Connect the hoses to their respective adapters on the manifold.
7. Install adapters (**60089**) to ports "P" & "T" on the manifold. Connect hydraulic hose (**60086**) to adapters. Be careful not to over tighten the hose connections.
8. Install the wire harness.

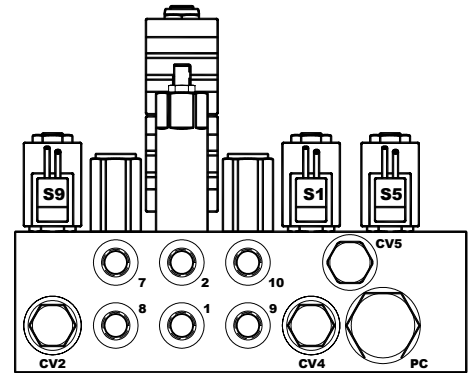

Ports #1, 2, 7, 8, 9 & 10.

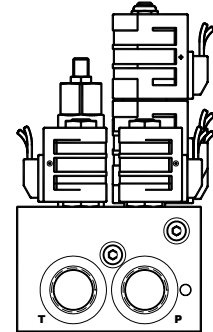

Ports "T" & "P".

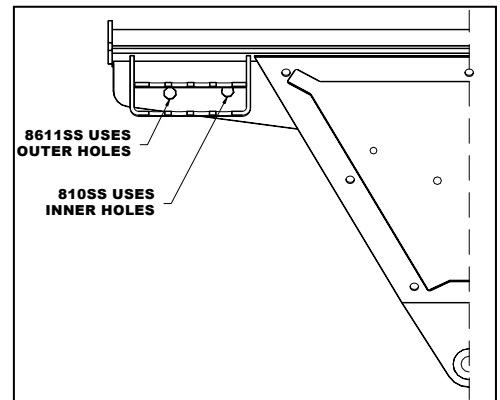

Angle Cylinder Mounting

Hydraulic Valve & Hose Port Guide

Models 810ss & 8611ss

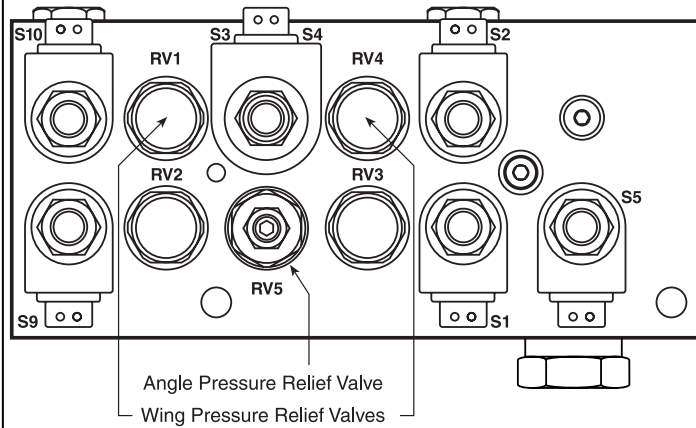

NOTE: Check valves CV1 & CV3 are not illustrated. Both valves are located on the opposite side of the manifold in the diagram shown below.

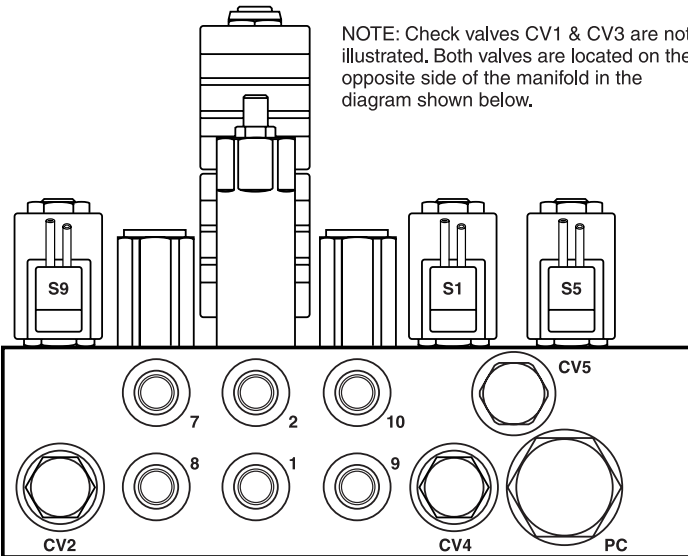

HYDRAULIC HOSES	
Port	Function
1	Right Angle - Left Cylinder
2	Left Angle - Right Cylinder
7	Left Slide Box Retract
8	Left Slide Box Extend
9	Right Slide Box Extend
10	Right Slide Box Retract
RELIEF & CHECK VALVES	
Valve	Function
RV1	Left Wing Pressure Relief
RV2	Left Wing Anti-Cavitation
RV3	Right Wing Anti-Cavitation
RV4	Right Wing Pressure Relief
RV5	Angle Relief
CV1	Left Slide Box Retract Check Valve
CV2	Left Slide Box Extend Check Valve
CV3	Right Slide Box Retract Check Valve
CV4	Right Slide Box Extend Check Valve
CV5	Back Pressure Check Valve
NOTE: Energize the following solenoids for the functions:	
S1	Right Slide Box Retract
S2	Right Slide Box Extend
S3	Angle Left - Right Cylinder
S4	Angle Right - Left Cylinder
S9	Left Slide Box Retract
S10	Left Slide Box Extend



Calumet, Michigan 49913

BLZ 1067

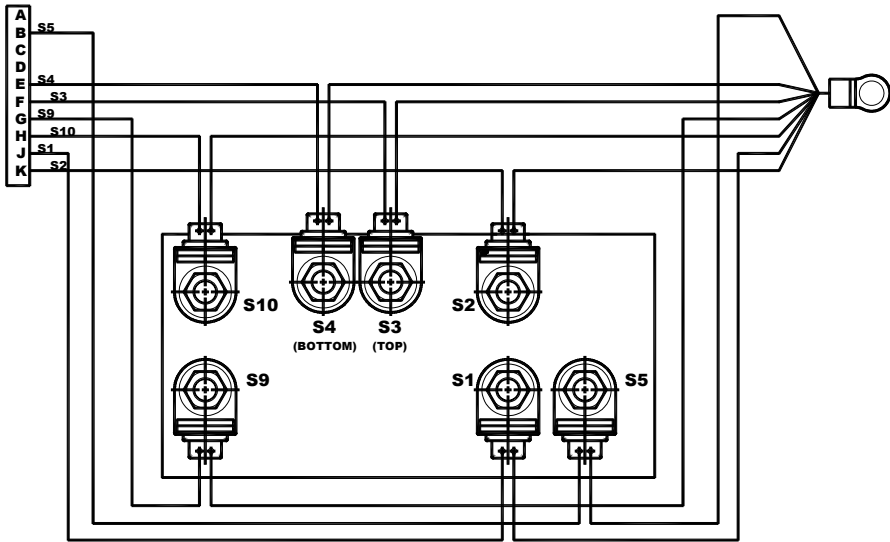

ELECTRICAL SCHEMATIC

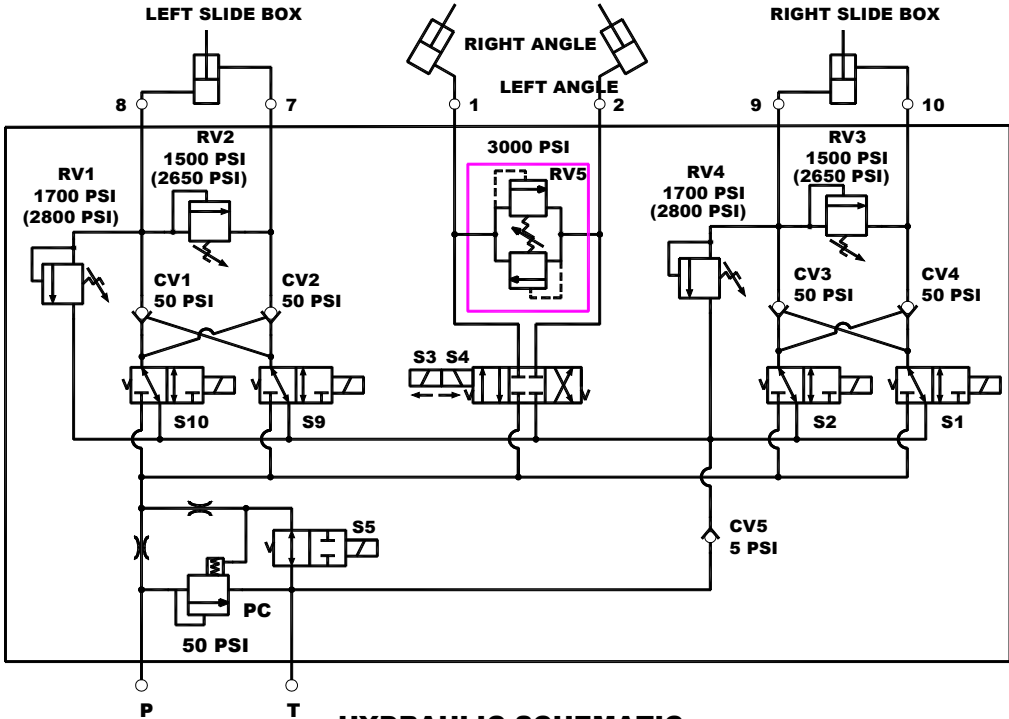

HYDRAULIC SCHEMATIC

NOTE: Where applicable, Model 8611SS values are in parenthesis.

ELECTRICAL-ASSEMBLY

1. Connect the manifold coil harness to the plow harness. Feed the opposite end of the plow harness through the top access hole in the A-frame (same as 3/4" tank hydraulic hose) located on the driver's side.
2. Attach the grounds on the coil wire harness and plow harness with a 3/8"-16 x 1-1/2" hex cap screw and 3/8" tooth lock washer to the A-frame. Secure the wires with a lock nut. Review the diagram for the proper ground location.
3. Connect the plow harness to the vehicle harness, and then the vehicle harness to the pistol grip control harness. Attach the ground wire from the vehicle harness to the cab of the skid steer. The pink/black power wire connects to a switched power source (on and off with ignition) with a minimum of 12 volts.
4. Position the vehicle harness mount bracket in an accessible location for easy on-and-off installation inside the skid steer. Secure the vehicle side harness in the notch on the bracket.
5. Position the control harness mount bracket vertically or horizontally for user preference inside the skid steer. Secure with hardware provided. Position the pistol grip control into the bracket and "twist-lock" it into place. *NOTE: Install the bracket so it does not interfere with any safety devices that might rotate in front of the operator.*
6. Complete the assembly by attaching the A-frame cover. Align the holes in the cover with those on the A-frame and secure it with 3/8"-16 x 1-1/2" hex cap screws and 3/8" washers.
7. Mount your plow to the skid steer, and then test all functions.

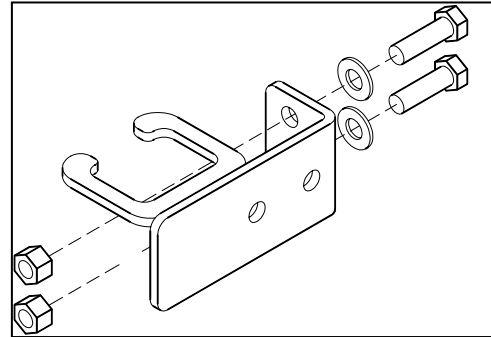
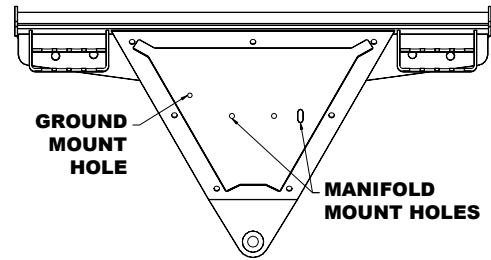

Control Mount Bracket (70048)

**SS PISTOL GRIP CONTROL HARNESS SCHEMATIC (62131);
INCLUDES 62132, 62133, 62134, 62135, 62136, 62210, 62211&
62219**

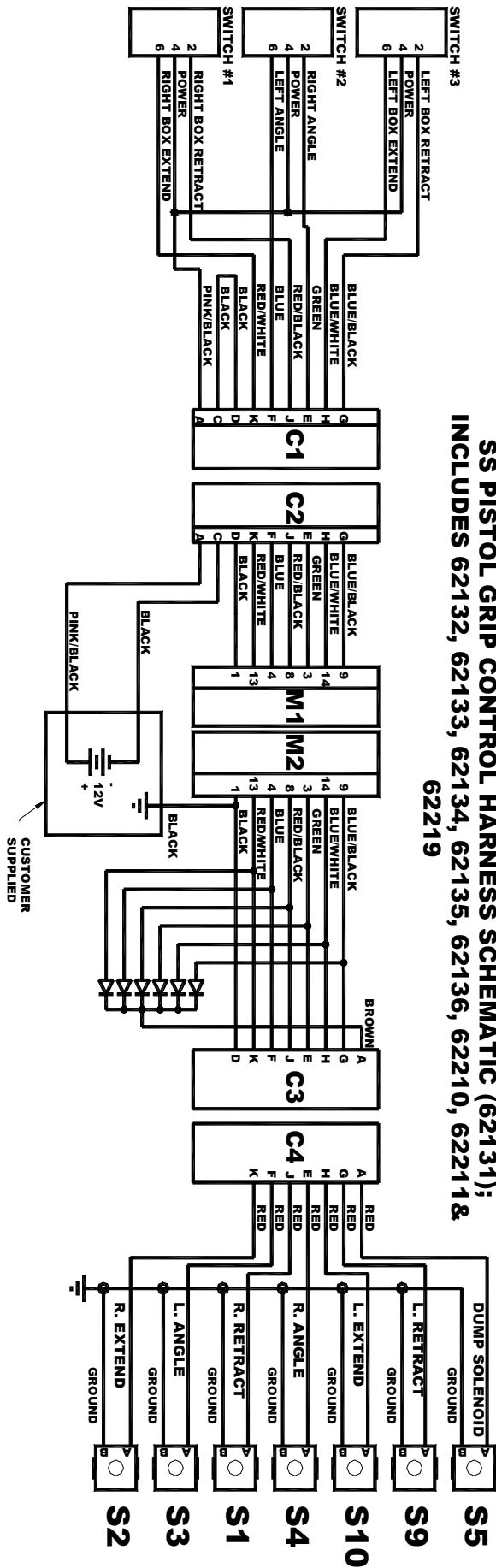

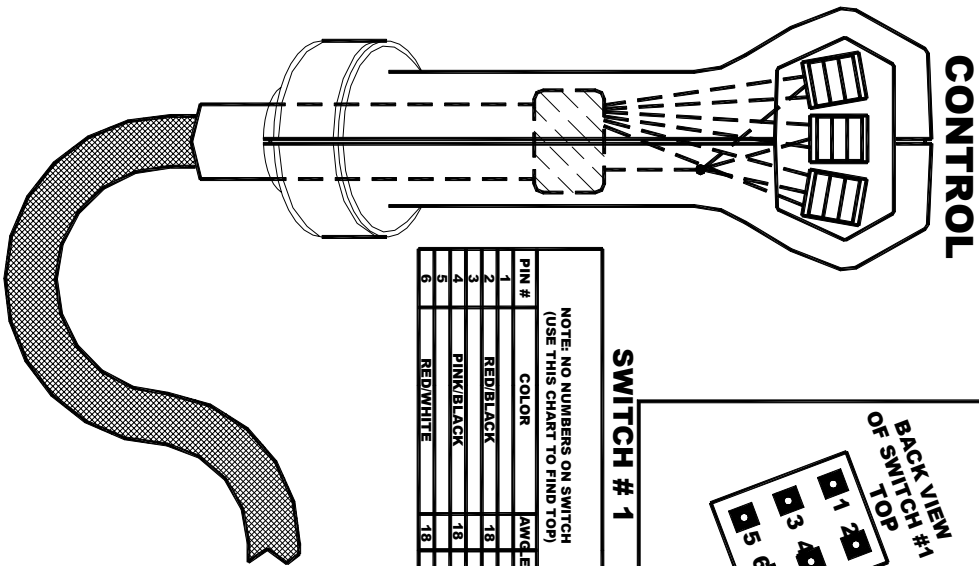

CONTROL

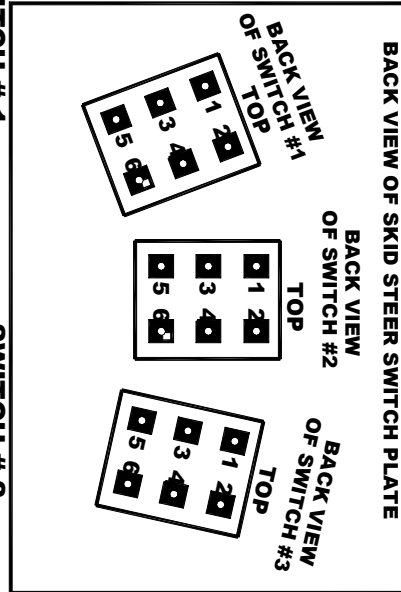

SWITCH # 1

NOTE: NO NUMBERS ON SWITCH
(USE THIS CHART TO FIND TOP)

PIN #	COLOR	AWG	LENGT
1	REDBLACK	18	84"
2	REDBLACK	18	84"
3	PINK/BLACK	18	6"
4	PINK/BLACK	18	6"
5	REDBLACK	18	84"

SWITCH # 2

NOTE: NO NUMBERS ON SWITCH
(USE THIS CHART TO FIND TOP)

PIN #	COLOR	AWG	LENGT
1	GREEN	18	84"
2	GREEN	18	84"
3	PINK/BLACK	18	6"
4	PINK/BLACK	18	6"
5	BLUE	18	84"

SWITCH # 3

NOTE: NO NUMBERS ON SWITCH
(USE THIS CHART TO FIND TOP)

PIN #	COLOR	AWG	LENGT
1	BLU/BLACK	18	84"
2	BLU/BLACK	18	84"
3	PINK/BLACK	18	6"
4	PINK/BLACK	18	6"
5	BLU/WHITE	18	84"

PIN #	COLOR	FUNCTION	AWG
A	PINK/BLACK	POWER	18
B	N/A	N/A	N/A
C	BLACK	GROUND (JUMPER)	18
D	BLACK	GROUND (JUMPER)	18
E	GREEN	RIGHT ANGLE	18
F	BLUE	LEFT ANGLE	18
G	BLU/BLACK	LEFT BOX RETRACT	18
H	BLU/WHITE	LEFT BOX EXTEND	18
J	REDBLACK	RIGHT BOX RETRACT	18
K	REDBLACK	RIGHT BOX EXTEND	18

(JUMPER)

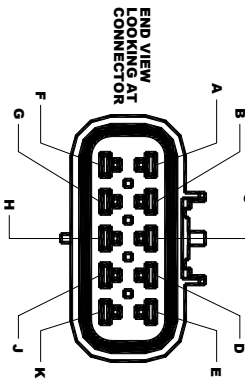

SS CONTROL HARNESS (62210, 62211 & 62219)

C1

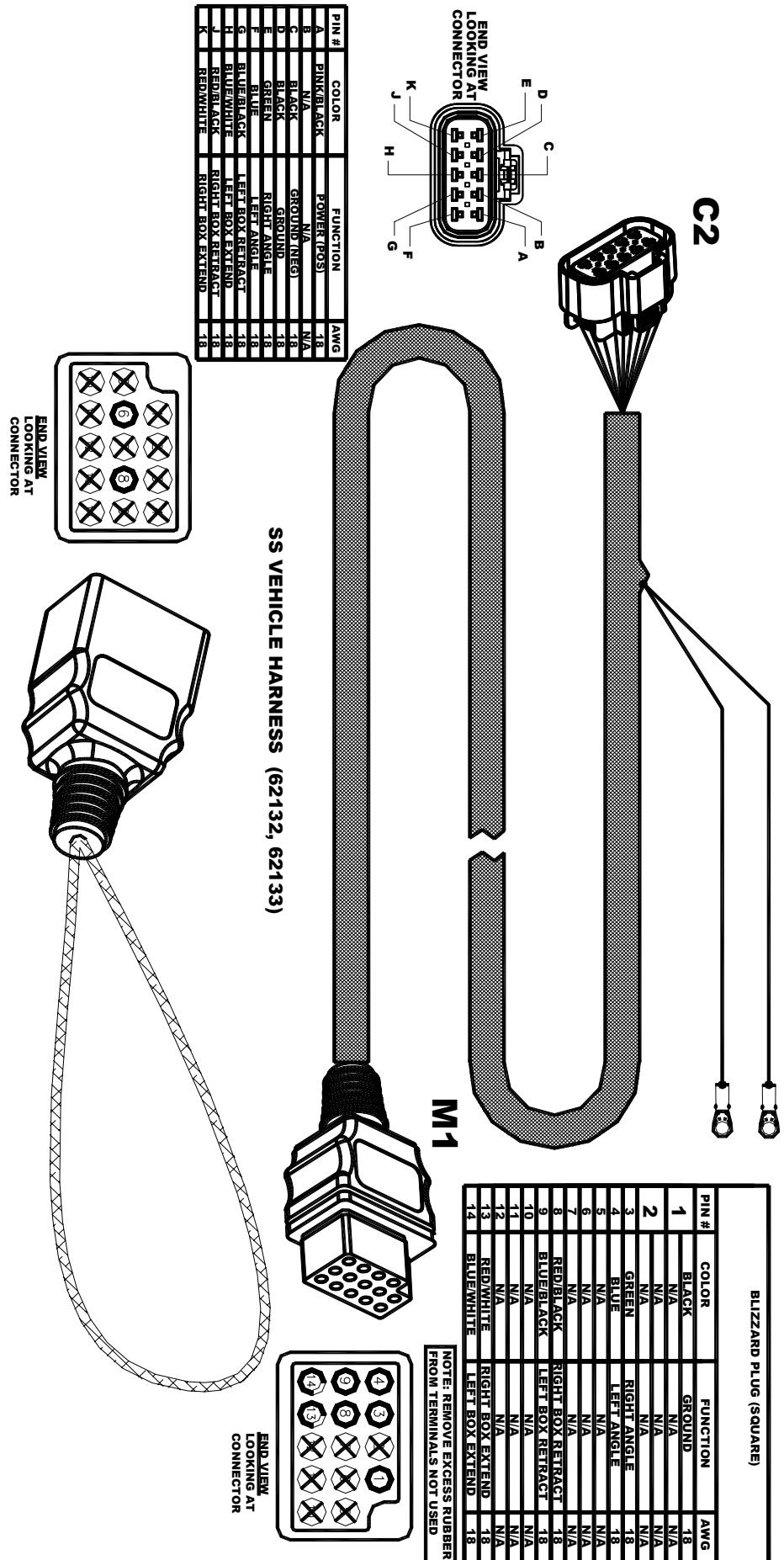

PIN #	COLOR	FUNCTION	AWG
A	PINK/BLACK	POWER (POS)	18
B	N/A	N/A	N/A
C	BLACK	GROUND (NEG)	18
D	BLACK	GROUND	18
E	GREEN	RIGHT ANGLE	18
F	BLUE	LEFT ANGLE	18
G	BLUE/BLACK	LEFT BOX RETRACT	18
H	BLUE/WHITE	LEFT BOX EXTEND	18
J	RED/BLACK	RIGHT BOX RETRACT	18
K	RED/WHITE	RIGHT BOX EXTEND	18

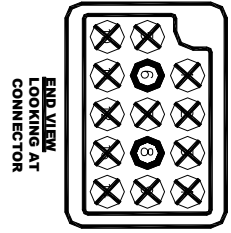
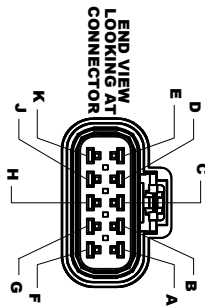

SS VEHICLE HARNESS (62132, 62133)

BLIZZARD PLUG (SQUARE)			
PIN #	COLOR	FUNCTION	AWG
1	BLACK	GROUND	18
2	N/A	N/A	N/A
3	N/A	N/A	N/A
4	GREEN	RIGHT ANGLE	18
5	N/A	N/A	N/A
6	N/A	N/A	N/A
7	N/A	N/A	N/A
8	RED/BLACK	RIGHT BOX RETRACT	18
9	BLUE/BLACK	LEFT BOX RETRACT	18
10	N/A	N/A	N/A
11	N/A	N/A	N/A
12	N/A	N/A	N/A
13	RED/WHITE	RIGHT BOX EXTEND	18
14	BLUE/WHITE	LEFT BOX EXTEND	18

NOTE: REMOVE EXCESS RUBBER FROM TERMINALS NOT USED

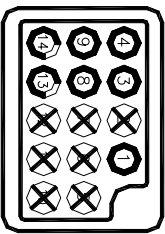

END VIEW
LOOKING AT
CONNECTOR

ELECTRICAL- ASSEMBLY

BLIZZARD PLUG (SQUARE)			
PIN #	COLOR	FUNCTION	AWG
1	BLACK	GROUND	18
	N/A	N/A	N/A
2	N/A	N/A	N/A
	N/A	N/A	N/A
3	GREEN	RIGHT ANGLE	18
4	BLUE	LEFT ANGLE	18
5	N/A	N/A	N/A
6	N/A	N/A	N/A
7	N/A	N/A	N/A
8	RED/BLACK	RIGHT BOX RETRACT	18
9	N/A	N/A	N/A
10	BROWN	PUMP SOLENOID	18
11	N/A	N/A	N/A
12	N/A	N/A	N/A
13	RED/WHITE	RIGHT BOX EXTEND	18
14	BLUE/WHITE	LEFT BOX EXTEND	18

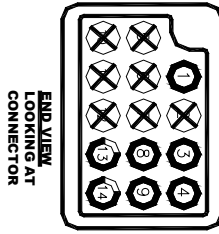

SS PLOW HARNESS (62134, 62135)

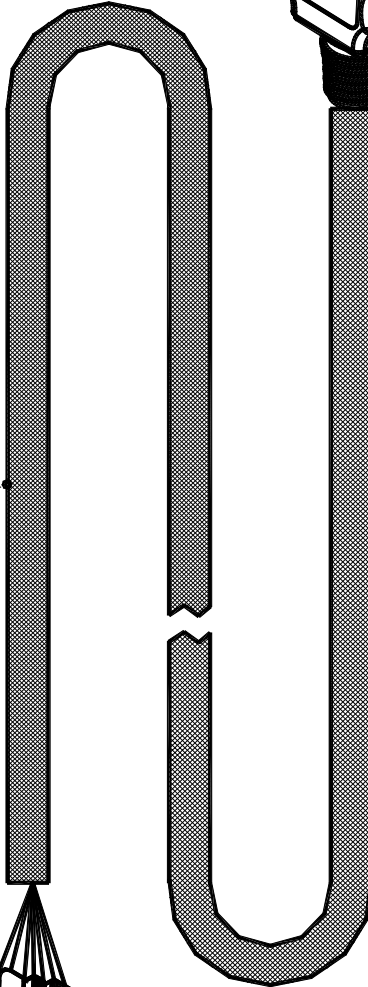

PIN #	COLOR	FUNCTION	AWG
A	BROWN	DUMP SOLENOID	18
B	N/A	N/A	N/A
C	N/A	N/A	N/A
D	BLACK	GROUND	18
E	GREEN	RIGHT ANGLE	18
F	BLUE	LEFT ANGLE	18
G	BLUE/BLACK	LEFT WING RETRACT	18
H	BLUE/WHITE	LEFT WING EXTEND	18
J	RED/BLACK	RIGHT WING RETRACT	18
K	RED/WHITE	RIGHT WING EXTEND	18

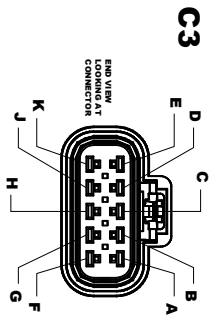
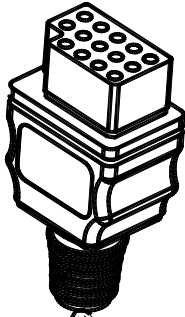
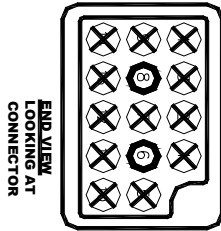

C3

SS COIL HARNESS (62136)

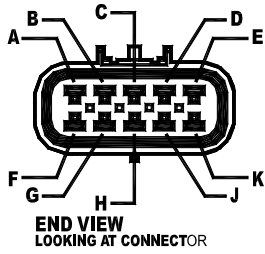

C4 CONNECTS TO C3
 PLASTIC ELECTRIC CONNECTOR - MALE (P/N 62045)
 SILICONE RUBBER CABLE SEAL (18WG) - P/N 62096
 MALE TERMINAL (18-18WG) - P/N 62097

3/8" END RING TERMINAL
 P/N 62118

COILS-10VDC
 P/N 62114 STAMPING ON
 MANIFOLD

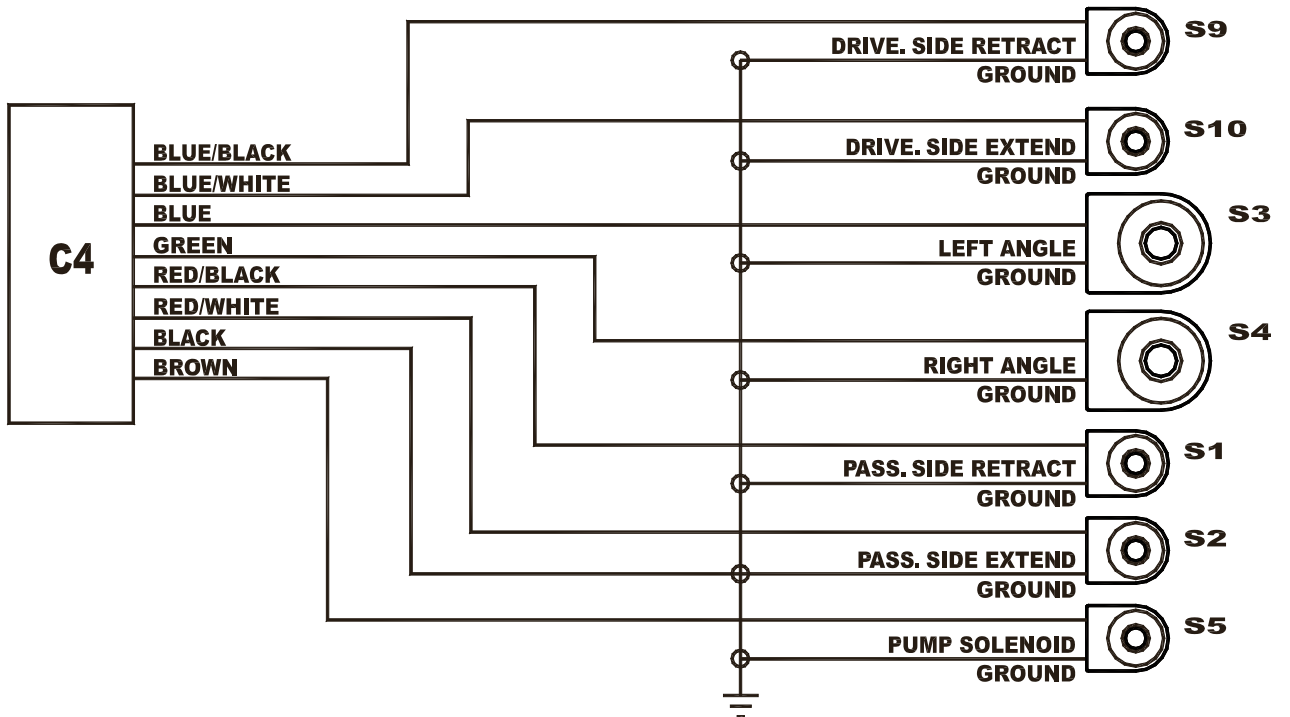
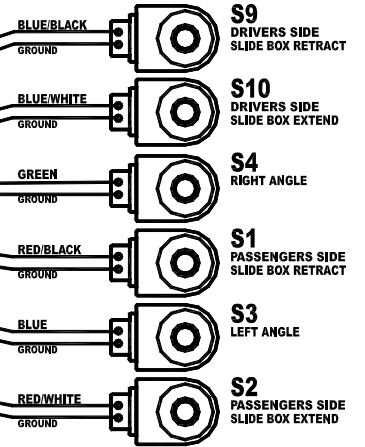

AUXILIARY CONTROL HARNESS W/ DIODES (OPTIONAL)

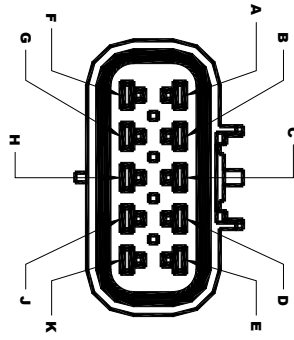

AUXILIARY CONTROL HARNESS W/ DIODES (62166)

PIN #	COLOR	FUNCTION	AWG
A	N/A	N/A	N/A
B	BROWN	PUMP SOLENOID	18
C	N/A	N/A	N/A
D	BLACK	GROUND	18
E	GREEN	RIGHT ANGLE	18
F	BLUE	LEFT ANGLE	18
G	BLUE/BLACK	LEFT BOX RETRACT	18
H	BLUE/WHITE	LEFT BOX EXTEND	18
J	RED/BLACK	RIGHT BOX RETRACT	18
K	RED/WHITE	RIGHT BOX EXTEND	18

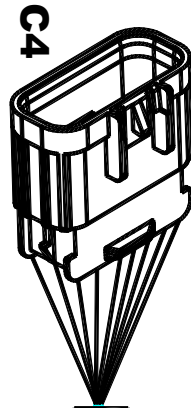
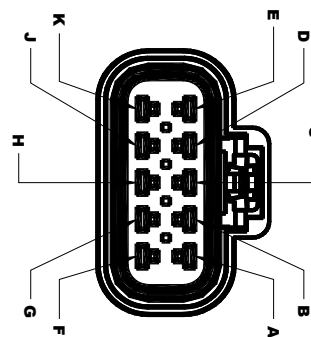

PIN #	COLOR	FUNCTION	AWG
A	N/A	N/A	N/A
B	N/A	N/A	N/A
C	N/A	N/A	N/A
D	BLACK	GROUND (JUMPER)	18
E	GREEN	RIGHT ANGLE	18
F	BLUE	LEFT ANGLE	18
G	BLUE/BLACK	LEFT BOX RETRACT	18
H	BLUE/WHITE	LEFT BOX EXTEND	18
J	RED/BLACK	RIGHT BOX RETRACT	18
K	RED/WHITE	RIGHT BOX EXTEND	18

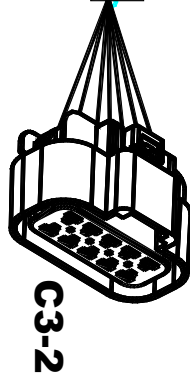
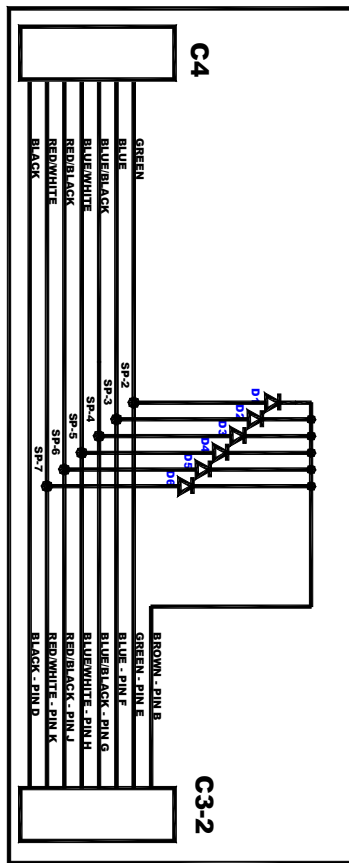

MOUNTING & DISMOUNTING INSTRUCTIONS

Prior to operating your Power Plow® snowplow, review the Mounting and Dismounting Instructions label on the back of the driver's side moldboard.

NOTE: If at any time the Mounting and Dismounting Instructions label, or any other label attached to your snowplow become illegible, promptly replace them.



810 SS-8611 SS SKID STEER

SKID STEER MOUNTING & DISMOUNTING INSTRUCTIONS

MOUNTING

1. Position the skid steer close to the snowplow attachment and align the mount points on the skid steer plate to those on the plow attachment plate.
2. Tilt the skid steer plate forward and position the top edge of the plate under the receiving pocket on the top edge of the snowplow attachment plate.
CAUTION: Keep fingers away from skid steer mounting points. Slightly raise the arms on the skid steer and tilt the skid steer plate toward the cab. The snowplow attachment should now be flush with the skid steer mount.
3. Engage both locking levers on the skid steer by rotating each handle 90° into a horizontal position. The attachment is now properly fastened to the skid steer.
4. Proceed to attach both 3/4" diameter hydraulic hoses from the manifold to the auxiliary hydraulic connections located on the skid steer. Note: Depending on the skid steer model, it may be necessary to initiate an auxiliary hydraulic switch on the skid steer prior to operating the plow.
5. Complete the electrical connection from the plow wire harness to the pistol grip control (or auxiliary electrical connection) on the skid steer.

DISMOUNTING

1. Lower the attachment on a flat, level surface and turn the engine off.
2. Disconnect the electrical connection for the plow controls.
3. Disconnect both 3/4" diameter hydraulic hoses from the auxiliary hydraulic connectors.
4. Disconnect the snowplow attachment by rotating both of the locking levers 90° until they are in the vertical position.
5. Start engine and slowly tilt the skid steer plate forward until the top edge of the plate clears the plow attachment plate.
6. Back skid steer away slowly – The disconnect procedure is now complete.

 **WARNING: Read and understand all warning labels prior to operating your skid steer attachment. Failure to follow this instruction may result in serious injury or death.**

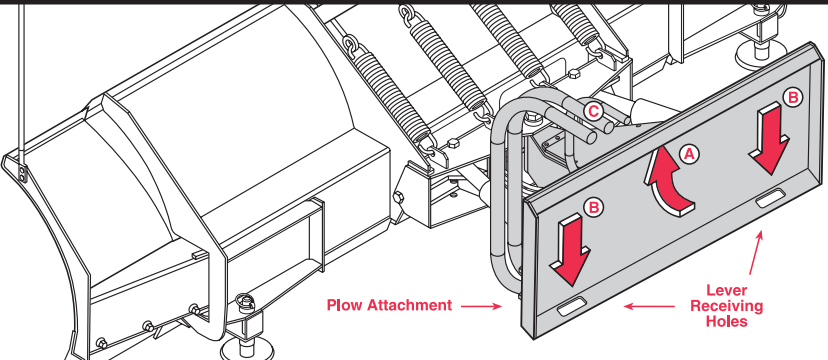

A Skid steer plate attaches under the top lip of the snowplow attachment.

B With the attachment flush to the skid steer plate, engage both locking levers on the skid steer. Rotate each handle 90° into a horizontal position. The levers will slide through the receiving holes in the snowplow attachment plate. The plate is now securely mounted to the skid steer.

C Connect both hydraulic hoses & the electrical harness to the skid steer.

BLZ 1014

TESTING

1. To test all of the functions on the Power Plow, your snowplow needs to be properly attached to the skid steer. Refer to the Mounting & Dismounting label on the back of the plow.
2. Complete the hydraulic connections with the skid steer turned off. *Note: Due to the various make and model skid steer available, hydraulic couplings for the auxiliary hydraulic connections are not provided. Consult your skidsteer's Operation Manual for the appropriate couplings needed.* Connect the couplings to the hoses for the pressure port ("P") and the tank port ("T") on the manifold. Complete the hydraulic installation by making the appropriate connections at the skid steer.

 **WARNING: Always use caution when connecting high-pressure hydraulic fittings. Hydraulic fluid under pressure can puncture skin causing serious injury or death. In the event of a hydraulic leak, relieve hydraulic pressure before loosening fittings. If injured, seek emergency medical help immediately.**

3. Start the skid steer and begin to initiate the Power Plow's blade functions. *Note: Depending on the skid steer model, it may be necessary to turn on the skid steer's auxiliary hydraulic switch prior to operating the plow.* The left switch operates the driver's side wing. Push the switch "up" to extend the wing and "down" to retract the wing. Push the center switch "up" to angle left and "down" to angle right. The right switch operates the passenger's side wing and works the same as the left switch. Upon initiating the switches on the pistol grip control, you may notice a plow function is slow or delayed. The hydraulic fluid is filling the cylinders and replacing air in the system. Monitor the hydraulic fluid level in your skid steer, and fill as necessary.

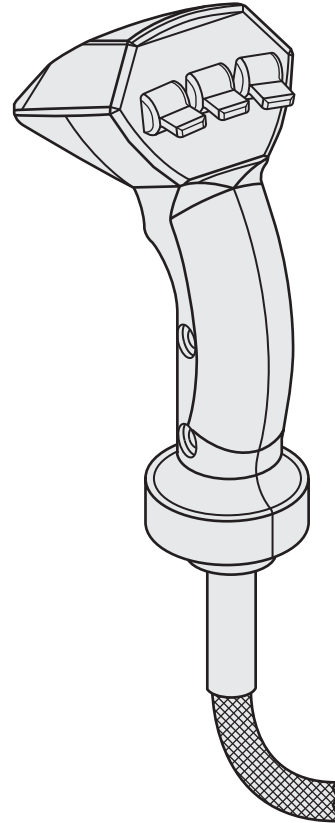

MAINTENANCE	PERIODICALLY	YEARLY
Check fasteners for tightness. Torque to specifications.	X	
Check hoses for wear and leaks.	X	
Check cylinders for leaks; inspect rod ends for corrosion & pitting	X	
Lubricate all exposed cylinder rod ends with liquid white lithium grease to prevent corrosion.		X
Check cutting edges and plow shoes for wear. <i>NOTE: Do not discard plow shoe washers, these should be retained for different shoe adjustments.</i>	X	
Clean and lubricate all electrical plugs and connections with dielectric grease. Clean and install all dust caps prior to storing.	X	X
Lubricate all pins and bushings, inner slide box and A-frame latch with NLGI Grade 2 multi-purpose lithium complex grease with molybdenum (MPGM)) to maintain consistent operation	X	X
Clean and paint all scratches or exposed metal with Blizzard touch-up paint	X	X
Check the hydraulic oil level. Never mix different types of fluid.	X	
Change the hydraulic fluid as specified in your Skid Steer owner's manual.		X
Check the trip spring adjustment. Properly adjusted tension will allow a sheet of paper to pass between the 3rd and 4th coils of the spring.	X	
Adjust the wing spring as needed or install an optional second extension spring for increased return speed.	X	
Pressure wash and dry the entire snowplow prior to storing		X
Cover the snowplow with a tarp if stored outside. This will protect your plow from sun fading and inclement weather which can lead to accelerated corrosion.		X

REMOVING FROM STORAGE

1. Perform all regular maintenance.
2. Replace the hydraulic fluid in the hydraulic system. Prolonged storage could result in condensation build-up.
3. Follow the mounting procedure on the Mounting & Dismounting label.
4. Initiate all of the functions & test before using.

TROUBLESHOOTING

PROBLEM	CAUSE	SOLUTION
Plow functions will not work after all connections are made or plow functions are slow.	S5 coil is not magnetizing.	S5 coil should magnetize with each function.
	Solenoid cartridge valve may be contaminated or damaged. A bent or over torqued cartridge will not allow the valve to move freely inside of the cartridge.	Determine a damaged cartridge valve by reversing the driver's side and passenger's side cartridge valves one at a time. Replace valve if necessary.
Plow functions start and terminate suddenly.	Skid steer hydraulic fluid flow is set to variable flow.	For plow functions to work, the skid steer hydraulic fluid flow should be set to continuous flow. Review your skid steer operation manual for proper flow settings.
Multiple valves function simultaneously.	Diodes may be corroded or damaged.	Clean diodes thoroughly and/or replace.
	Wire harness may be damaged.	Verify harness is not damaged. Review schematic(s) to troubleshoot connection(s). Replace if needed.
Plow functions are reversed (i.e. Driver's side wing extends when passenger's side wing is activated from the control.)	Hydraulic hoses are connected wrong or coils and wiring are incorrect.	Review the Hydraulic Valve & Hose Port Identification Guide under the A-frame cover for proper port locations and/or place respective coils over correct valves.
Both wings extend when the skid steer hydraulics are turned on.	Pressure (P) and tank (T) hoses are installed in the wrong position on the skid steer.	Review the skid steer operation manual to determine the pressure and tank connections.
Plow angles only one way.	Skid steer computer conflicts with cylindrical connection.	Using a jumper wire, connect pin K to pin L at the back of the cylindrical connector (cylindrical connector only).
Wing will not stay angled when plowing.	The wing pressure relief valve is contaminated.	Test the wing pressure relief. Attach a T-fitting with a fluid PSI gauge to the base end of the wing cylinder. Pressure relief should not be greater than 1700PSI (2800PSI for 8611SS) Replace if less than 1500-1700PSI (2600-2800PSI).
Plow will not stay angled when plowing.	The angle pressure relief valve is set too low. <i>NOTE: Increasing the pressure relief valve will cause damage to your plow. Do not set the pressure relief greater than 3000PSI.</i>	Follow the guidelines indicated above; however, the PSI setting should not exceed 3000PSI. <i>NOTE: If the plow is floating back when angled to the right, adjust the left pressure relief valve and vice versa.</i>
Wing will not move.	Control station, harness or cables may be loose or improperly connected.	Verify control station, harness and all cables are securely connected. Clean if necessary.
	No power to the cartridge valve.	Verify S9 & S10 coils (passenger's side slide box retract and extend) and S1 & S2 (driver's side slide box retract and extend) are connected properly. Diagnose the wire harness. Review all wire harness schematics. If power is present, review the next step.
Wing will not move.	Coils are receiving power.	Verify coils are magnetizing. Position a screwdriver inside of the coil. When the respective function is activated, the screwdriver is drawn to the side of the coil. If the coil is not drawn to the screwdriver, replace the coil. If power is present, review the next step.
Plow will not angle.	Solenoid cartridge may be contaminated or damaged. A bent cartridge will not allow the valve to move freely inside of the cartridge.	Determine a damaged cartridge valve by reversing the driver's side and passenger's side cartridge valves. Replace valve if necessary.
	Review all probable causes above.	<i>NOTE: Verify coils S3 & S4 for angle functions.</i>

Should your snowplow develop other problems not indicated, contact your local Dealer for technical assistance and/or replacement parts.

MOLDBOARD & WING PARTS

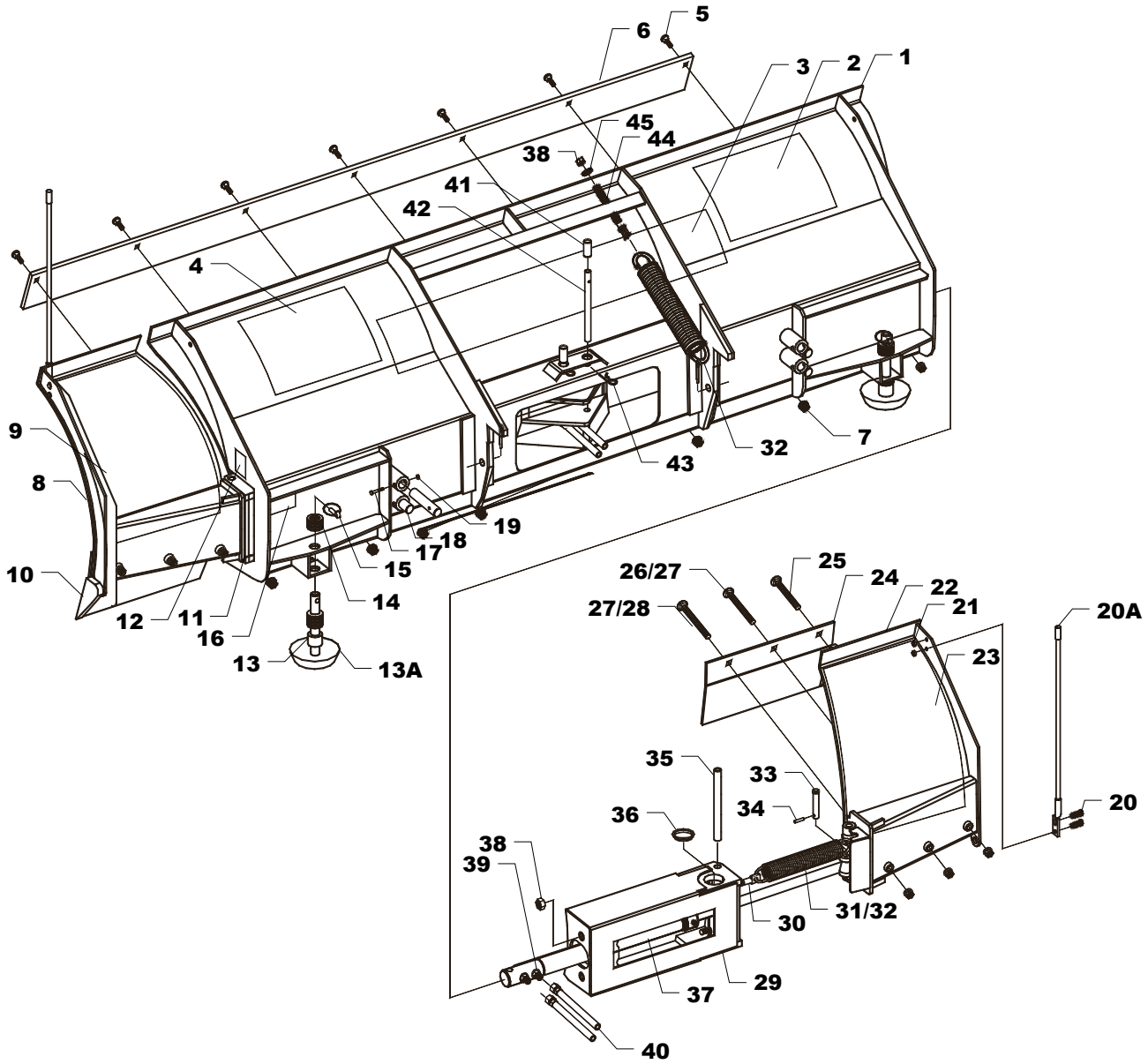

MOLDBOARD & WING PARTS

REF	PART NUMBER	QUANTITY		DESCRIPTION
		810SS	8611SS	
1	52074	1	-	Moldboard Weldment
	52085	-	1	
2	61170	1	1	Label, WARNING! (Blz1013)
3	63160	1	1	Decal, Center Moldboard (Blz1070)
4	61171	1	1	Label, Skid Steer Mounting & Dismounting (Blz1014)
5	61292	1	-	Cutting Edge, Moldboard (1080)
	52139	-	1	
6	61196	7	-	Bolt, 1/2"-13 x 1-1/2" Carriage Gr8
	61623	-	7	
7	61365	13	6	Nut, 1/2"-13 Flanged Lock Z
	61626	-	7	
8	51042	1	-	Wing Weldment, Driver's Side
	51100	-	1	
9	61083	1	-	Decal, Wing, Driver's Side
	63065	-	1	
10	51048	1	-	Cutting Edge, Weldment Driver's Wing (T1)
	51069	-	1	
11	50057	1	-	Slide Box, Weldment Drivers
	50075	-	1	
12	63113	2	2	Label, Warning! Multiple Pinch Points (Blz1068)
13A	61220	2	2	Plow Shoe Asm, Heavy-Duty Cast Iron (8-3/8" Shaft) Includes Ref 13-15
13	61102	2	2	Spacer, 1-1/8" I.D., 1-5/8" O.D. x 1-1/2" YZ
14	61101	36	36	Washer, 1" Flat YZ
15	61103	2	2	Pin, 7/16" x 1-3/4" Linch YZ
16	63063	1	1	Label, Serial Number, Sequentially Numbered (Blz1049)
17	61383	4	4	Screw, 5/16"-18 x 2-1/4" HHCS Gr8 YZ
18	11871	4	4	Pin, 1" Dia. x 4-3/4" Slide Box Stop (with 3/8" Dia. hole)
19	61384	4	4	Nut, 5/16"-18 Top Lock Z
20A	61049	2	2	Plow Guide Assembly Includes Ref 20-21
20	61051	4	4	Screw, 5/16"-18 x 1" HHCS Gr5 Z
21	61052	4	4	Nut, 5/16"-18 Nylock Z
22	51043	1	-	Wing Weldment, Passenger's Side
	51101	-	1	
23	61084	1	-	Decal, Wing, Passenger's Side
	63064	-	1	
24	51047	1	-	Cutting Edge, Weldment Passenger's Wing (T1)
	51070	-	1	
25	61418	2	-	Bolt, 1/2"-13 x 3-1/2" Carriage Gr8 P
	61360	-	2	
26	61419	2	-	Bolt, 1/2"-13 x 4-1/2" Carriage Gr8 P
27	61361	2	2	Bolt, 1/2"-13 x 5-1/2" Carriage Gr8 P
28	61362	-	2	Bolt, 1/2"-13 x 6-1/2" Carriage Gr8 P
29	50058	1	-	Slide Box, Weldment Passenger
	50074	-	1	
30	61416	2	2	Bolt, 5/8"-11 x 7-3/8" Spade Gr8 Z
31	61398	2	-	Spring, 13" O.A.L. x 2" O.D. x 5/16" Extension
32	61099	4	8	Spring, 15-1/4" O.A.L. x 2-3/8" O.D. x 3/8" Extension
33	61385	2	2	Pin, 5/8" Dia. x 3" Clevis YZ
34	61028	2	2	Pin, 1/4" Dia. x 1-1/4" Spring
35	51009	2	-	Pin, 3/4" Dia. x 9" Wing/Slide Box Pivot
	13307	-	2	
36	61425	2	-	Plug, 2-51/64" O.D., 2-9/32" I.D. x 1/2" Black Polyethylene
37	60347	2	-	Hydraulic Cylinder, Slide Box Extend/Retract
	60207	-	2	
38	61063	2	8	Nut, 5/8"-11 Top Lock Z
39	60007	4	-	Hydraulic Adapter, 9/16"-18 x 9/16"-18 Male O.R.B.
	60272	-	4	
40	60224	4	4	Hydraulic Adapter, 9/16"-18 x 9/16"-18 45° Adjustable Elbow O.R.B.
41	61198	2	2	Hydraulic Hose, 3/8" x 36" (Ports #7, 8, 9 & 10) Slide Box Extend/Retract
42	11989	2	2	Cap, 5/8" I.D., 3/4" O.D. x 1" Black Vinyl
43	61030	2	2	Pin, 5/8" Dia. x 11-1/2" Hydraulic Cylinder Base End (with 1/4" Dia. hole) - Slide Box Extend/Retract
44	61187	4	6	Pin, 1/8" Dia. x 2-5/8" Hair Cotter Z
45	61064	4	6	Bolt, 5/8"-11 x 6-3/8" Spade Gr8 Z
				Washer, 5/8" SAE Hardened YZ

A-FRAME & PIVOT BEAM PARTS

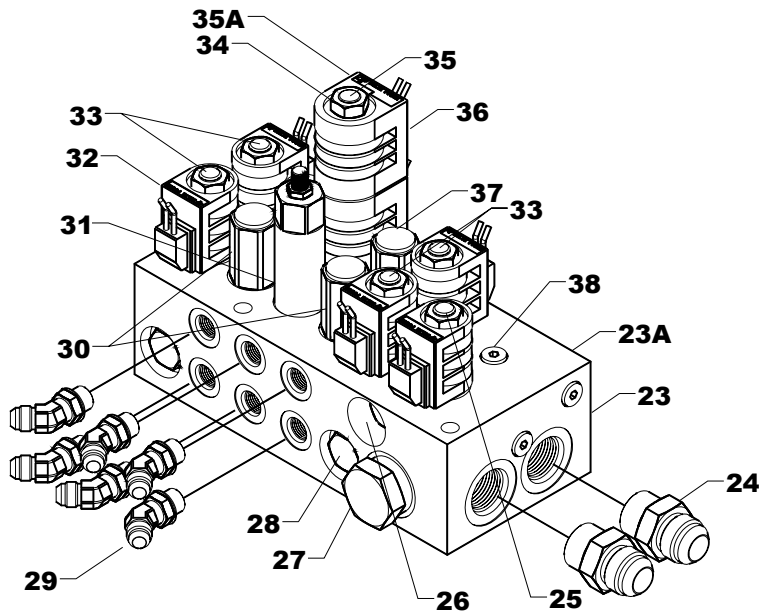
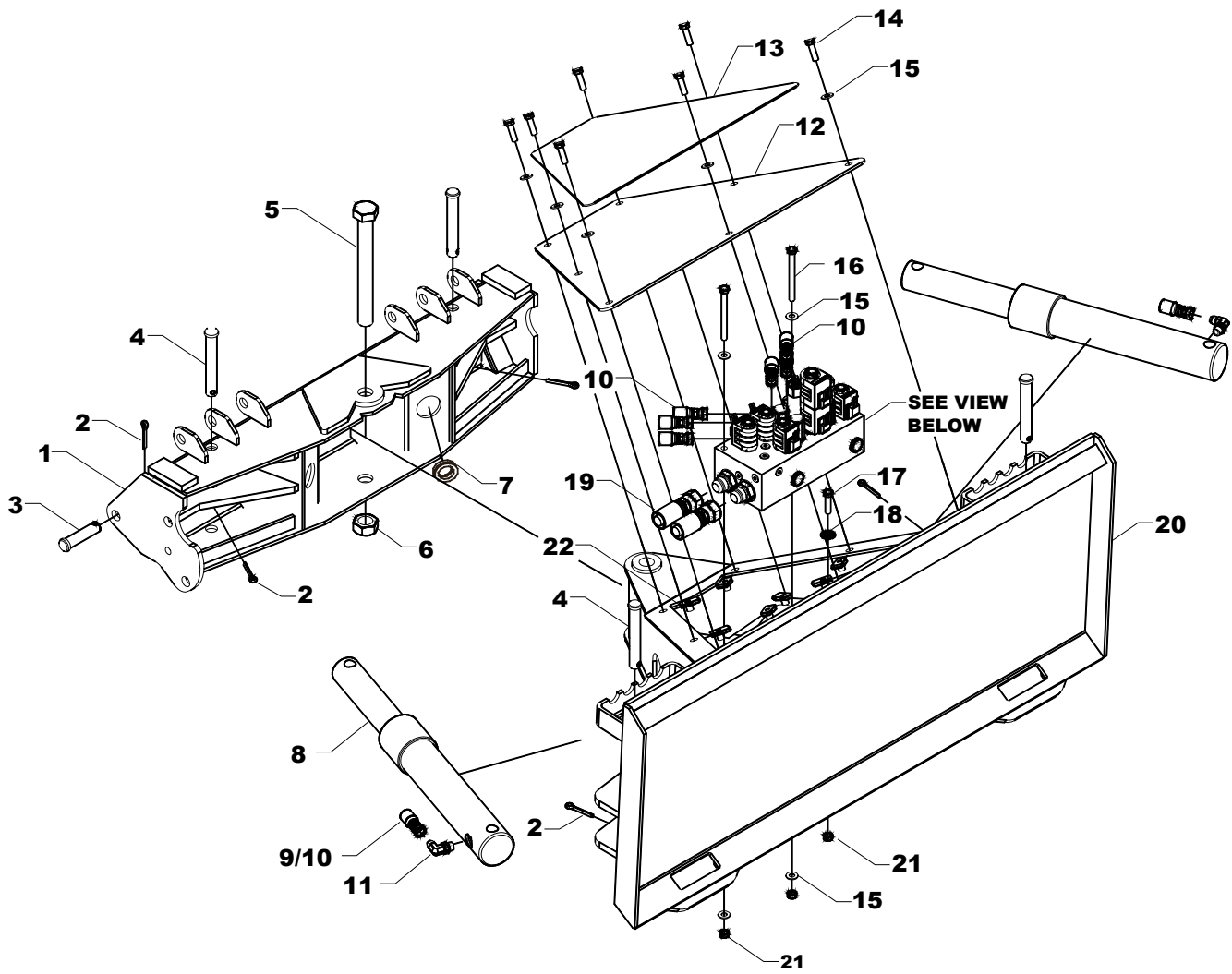

A-FRAME & PIVOT BEAM PARTS

REF	PART NUMBER	QUANTITY		DESCRIPTION
		810SS	8611SS	
1	41041	1	-	Pivot Beam Weldment
	41052	-	1	
2	61357	6	6	Pin, Cotter, 1/4" x 1-1/2" Z
3	50069	2	2	Pin, 3/4"Dia. x 3" Clevis YZ
4	41051	4	4	Pin, 3/4"Dia. x 5" Clevis YZ
5	61331	1	1	Screw, 1"-8 x 9" HHCS Gr8 P
6	61008	1	1	Nut, 1"-8 Top Lock Z
7	61217	4	4	Grommet, 1-1/2" I.D., 2-1/8" O.D. Black Rubber, 60 Durometer
8	60029	2	-	Hydraulic Cylinder, Plow Angle
	60324	-	2	
9	60223	2	-	Hydraulic Hose, 3/8" x 26" Plow Angle
10	60224	4	6	Hydraulic Hose, 3/8" x 36" Plow Angle
11	60005	2	2	Hydraulic Adapter, 9/16"-18 x 9/16"-18 90° Adjustable Elbow O.R.B.
12	70143	1	1	Mat, A-Frame Rubber
13	70134	1	1	Plate, A-Frame Cover
14	61214	7	7	Screw, 3/8-16 UNC x 1-1/4" HHCS
15	61016	11	11	Washer, 3/8" SAE Hardened
16	61514	2	2	Screw, 3/8-16 UNC x 4 HHCS
17	61328	1	1	Screw, 3/8-16 UNC x 1-1/2" HHCS
18	61307	1	1	Washer, 3/8" Internal/External Tooth Lock
19	60086	2	2	Hydraulic Hose, 3/4"x78" -str./str.
20	70132	1	1	A-frame Weldment
21	61034	3	3	Nut, 3/8-16 UNC Hex Nylock
22	61275	7	7	U-Nut, 3/8-16 UNC
23A	60341	1	-	Manifold Assembly
	60342	-	1	
23	60354	1	-	Manifold Block (with Cross Port Relief), Clear Anodized Aluminum
	60355	-	1	Manifold Block (with Cross Port Relief), Gold Anodized Aluminum
24	60089	2	2	Hydraulic Adapter, 1 1/16-12 x 1 1/16-12 Male O.R.B. connector
25	60320	1	1	Valve, Spool Two-Way N.O.
26	60356	1	1	Valve, Back Pressure Check 5PSI
27	60183	1	1	Valve, Pressure Compensation Regulation
28	60225	4	4	Valve, Check, 50 PSI
29	60272	6	6	Hydraulic Adapter, 9/16-18 x 9/16-18 Adj. Elbow
30	60279	2	-	Valve, Relief, 1500PSI
	60227	-	2	Valve, Relief, 2650 PSI
31	60168	1	1	Valve, Relief, 3000 PSI
32	62163	5	5	Coil, PDL 12 VDC
33	60166	4	4	Valve, Spool, Three-Way, Two Position
34	60052	5	5	Nut, 1/2-20 Hex Jam, YZ
35A	62161	1	1	Coil Harness Assembly Includes 62045 (1), 62118 (2), 62116 (5), 62096 (7), 62097 (7), Ref 32 & 36
35	60321	1	1	Valve, Four Way-Three Position Spool
36	62164	2	2	Coil, LDL 12 VDC
37	60278	2	-	Valve, Relief 1700 PSI
	60226	-	2	Valve, Relief 2800 PSI
38	60049	2	2	Plug, SAE Hollow Hex O.R.B.
-	60322	2	2	Piston Assembly

HARNESSES, ACCESSORIES & KITS

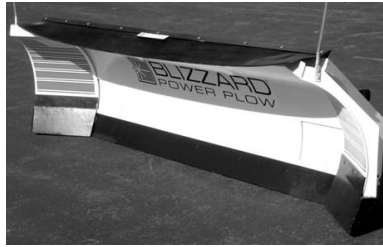
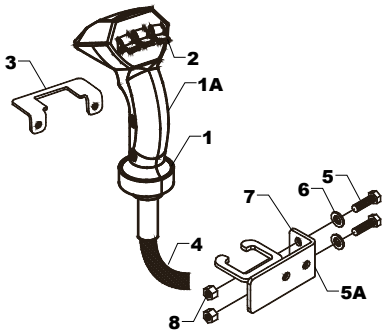

9. Rugged and durable, the 3/8" thick, 2-ply construction keeps snow off of your windshield and in its place—on the ground! The one piece rubber design allows for wing clearance and provides optimum snow deflection. The deflector is shipped with a "Blizzard Power Plow" vinyl decal and complete mounting hardware.



10. Integrate all snowplow controls into your skid steer using an optional auxiliary control harness. This 7 ft. braided harness connects easily to your existing manifold harness on one end and your skid steer on the other. Assembly of the harness wiring to your skid steer-specific auxiliary electrical controls required. Electrical connector not provided with harness.



11. Beef-up your Power Plow snowplow with our 3/8" thick wing cutting edges. These edges are built to withstand heavy plow use on the roughest road surfaces and also provide added material for protection against sidewalk curb wear. Mounting hardware included.



12. Turn your Blizzard Power Plow into an all-season skid steer blade with an easy to install trip-lock assembly. This one-piece accessory replaces the standard trip springs to provide a rigid grading blade. Now you can level and grade material in a fraction of the time! Trip-Lock assembly shipped complete with mounting hardware.

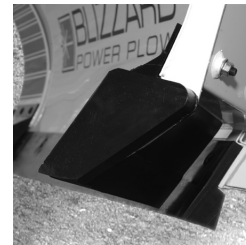

13. Durable and long lasting, the Power Plow polyurethane mold-board and wing cutting edges will keep you plowing longer and safer! Specially formulated for snowplowing applications, Blizzard polyedges resist gouging, provide superior wear life and effectively reduce plowing noise. Ideal for all plowing conditions. Edges are shipped with mounting hardware.



14. Putting your snowplow away for the winter? Have a deep scratch to cover? Clean up your blade and plow parts with our gloss spray paints. Blizzard snowplow touch-up paint provides an excellent finish to help keep your snowplow looking its best. Paint provided in 12 oz. spray cans.

HARNESSES, ACCESSORIES & KITS

REF	PART NUMBER	QUANTITY		DESCRIPTION
		810SS	8611SS	
1A	62131	1	1	Pistol Grip Control Wire Harness Assembly Includes Ref 1-8
1	62219	1	1	Housing, SS Pistol Grip 2 Halves w/ screws (61613)
2	62211	1	1	Circuit Board & 3 Switch Assembly
3	70040	1	1	Mount Bracket, Wire Harness Extension, Vehicle Side
4	62210	1	1	Harness, SS control w/ pipe
5A	70048	1	1	Pistol Grip Control Mount Bracket Kit Includes Ref 5-9
5	61214	2	2	Screw, 3/8"-16 x 1-1/4" HHCS Gr8 YZ
6	61016	2	2	Washer, 3/8" S AE Hardened YZ
7	70049	1	1	Mount Bracket, Pistol Grip Control
8	61014	2	2	Nut, 3/8"-16 Jam Nylock, Z Type NTE
-	62132	1	1	Wire Harness Extension, Vehicle Side
-	62133	1	1	Weather Cap, Vehicle Side Wire Harness Extension
-	62134	1	1	Wire Harness Extension, Plow Side
-	62135	1	1	Weather Cap, Plow Side Wire Harness Extension
-	62045	2	2	Connector, Electric, Male, Plastic
-	62097	17	17	Terminal, Male (18-16AWG)
-	62096	35	35	Seal, Cable, Silicone, Orange (18 AWG)
-	62116	5	5	Plug, Cavity, Silicone, White(18-16 AWG)
-	62046	2	2	Connector, Electric, Female, Plastic
-	62100	2	2	Terminal, Ring, #10 (22-18AWG)
-	62093	18	18	Terminal, Female (18-16AWG)
-	62118	1	1	Terminal, End Ring, 3/8"
-	62072	1	1	Terminal, End Ring, 3/8" Plow Side Wire Harness Extension
-	62218	1	1	Harness, SS Plow Side Extension 4'
9	61241	1	-	Rubber Snow Deflector w/ hardware
	52087	-	1	
10	62166	1	1	Auxiliary Control Harness w/ diodes
11	61288	1	-	3/8" Wing Cutting Edges w/ hardware (T1)
12	70028	1	-	Trip-Lock Assembly w/ hardware
	70056	-	1	
13	61536	1	-	Polyurethane Moldboard & Wing Cutting Edges (with Hardware)
	61539	-	1	
14	61219	1	1	Blizzard Power Plow High Performance 12 Oz. Spray Paint, Gloss White
	63073	1	1	Blizzard Power Plow High Performance 12 Oz. Spray Paint, Gloss Black
KITS				
-	61277	1	-	Kit, Hardware, Snowplow Assembly Parts
	61479	-	1	
-	60454	1	-	Kit, Hydraulic Adapter Includes 60005 (2), 60007 (4), 60089 (2), 60272 (6)
	60453	-	1	
-	60456	1	-	Kit, Hydraulic Hose Includes 60086 (2), 60223 (2), 60224 (4)
	60455	-	1	
-	61430	1	1	Kit, Hardware, Moldboard Cutting Edge
-	52067	1	-	Kit, Moldboard Cutting Edge w/Hardware
	52095	-	1	
-	61431	1	-	Kit, Hardware, Wing Cutting Edge
-	61387	-	1	Kit, Hardware, Wing Cutting Edge
-	51104	1	-	Kit, Wing Cutting Edges w/ Hardware
	51103	-	1	
-	60360	1	-	Combo Seal Kit, Cyl 60029/60065
-	60365	-	1	Combo Seal Kit, Cyl 60207
-	60366	-	1	Combo Seal Kit, Cyl 60221/60324
-	60373	1	-	Combo Seal Kit, Cyl 60347



SNOWPLOWS

LIMITED CONSUMER WARRANTY

This warranty covers defects in material and workmanship except as set forth below.

WARRANTED PARTY:

This warranty applies only to the "Original Purchaser" who purchased this plow from an Authorized Blizzard Dealer, for personal, family or household use.

TERM OF WARRANTY:

This Blizzard snowplow is warranted for the following period:
Parts and labor are warranted for one year from date of purchase.

BLIZZARD CORPORATION'S WARRANTY REMEDY:

Blizzard Corporation will, at its sole discretion, repair or replace defective parts at no charge.

CUSTOMERS RESPONSIBILITY:

To obtain warranty service, the purchaser must return the defective snowplow to any Authorized Blizzard Dealer. The purchaser must verify the original purchase date. Transportation costs to and from the dealer will be the responsibility of the purchaser.

ITEMS NOT COVERED UNDER THIS WARRANTY:

1. Expendable parts such as cutting edges, plow shoes, hoses, fasteners, blade guides, paint finish, etc.
2. Any snowplow or part thereof which has been repaired or altered by anyone other than an Authorized Blizzard Dealer.
3. Any snowplow or part thereof which has been subject to neglect, misuse, accident, improper installation, maintenance, or storage. This includes, but is not limited to, corrosion of any electrical components.
4. Snowplows mounted on vehicles other than those for whom Blizzard Corporation has provided a specific mount system.
5. Blizzard Corporation does not assume liability for damage to the purchaser's vehicle resulting from the attachment and use of a Blizzard snowplow. Vehicle risk is the sole responsibility of the purchaser.

WARRANTY LIMITATIONS:

THIS WARRANTY IS OFFERED IN LIEU OF ANY OTHER EXPRESS WARRANTY.

THE DURATION OF ALL IMPLIED WARRANTIES, INCLUDING BUT NOT LIMITED TO THE IMPLIED WARRANTIES OF MERCHANTABILITY AND FITNESS FOR A PARTICULAR PURPOSE, ARE LIMITED TO THE DURATION OF THIS WARRANTY.

BLIZZARD CORPORATION'S LIABILITY IS EXPRESSLY LIMITED TO REPAIR OR REPLACEMENT OF DEFECTIVE PARTS. BLIZZARD CORPORATION SHALL NOT BE LIABLE FOR CONSEQUENTIAL, INCIDENTAL OR CONTINGENT DAMAGES WHATSOEVER, EVEN IF DAMAGES ARE CAUSED BY THE NEGLIGENCE OR FAULT OF BLIZZARD CORPORATION.

State Laws: Some states do not allow exclusion of incidental or consequential damages or the limitations on how long an implied warranty lasts, so these limitations or exclusions may not apply to you. This warranty gives you specific legal rights and you may also have other rights which vary from state to state.

This warranty does not apply if you purchased your snowplow for other than personal, family, or household use. If purchased for other than personal, family or household use, refer to the Blizzard Snowplow Commercial Warranty.



95 AIRPARK BOULEVARD ■ CALUMET, MICHIGAN 49913 ■ [906] 482-5555

1410-4-05 REV 4/05



BLIZZARD[®]
SNOWPLOWS

COMMERCIAL WARRANTY

This warranty covers defects in material and workmanship except as set forth below.

WARRANTED PARTY:

This warranty applies only to the "Original Purchaser" who purchased this plow from an Authorized Blizzard Dealer, for commercial use.

TERM OF WARRANTY:

This Blizzard snowplow is warranted for the following period:
Parts and labor are warranted for one year from date of purchase.

BLIZZARD CORPORATION'S WARRANTY REMEDY:

Blizzard Corporation will, at its sole discretion, repair or replace defective parts at no charge.

CUSTOMERS RESPONSIBILITY:

To obtain warranty service, the purchaser must return the defective snowplow to any Authorized Blizzard Dealer within the warranty period. The purchaser must verify the original purchase date. Transportation costs to and from the Dealer will be the responsibility of the purchaser.

ITEMS NOT COVERED UNDER THIS WARRANTY:

1. Expendable parts such as cutting edges, plow shoes, hoses, fasteners, blade guides, paint finish, etc.
2. Any snowplow or part thereof which has been repaired or altered by anyone other than an Authorized Blizzard Dealer.
3. Any snowplow or part thereof which has been subject to neglect, misuse, accident, improper installation, maintenance, or storage. This includes, but is not limited to, corrosion of any electrical components.
4. Snowplows mounted on vehicles other than those for whom Blizzard Corporation has provided a specific mount system.
5. Blizzard Corporation does not assume liability for damage to the purchaser's vehicle resulting from the attachment and use of a Blizzard snowplow. Vehicle risk is the sole responsibility of the purchaser.

LIMITS OF BLIZZARD CORPORATION'S LIABILITIES:

BLIZZARD CORPORATION'S LIABILITY IS EXPRESSLY LIMITED TO REPAIR OR REPLACEMENT OF DEFECTIVE PARTS. BLIZZARD CORPORATION SHALL NOT BE LIABLE FOR CONSEQUENTIAL, INCIDENTAL OR CONTINGENT DAMAGES WHATSOEVER, EVEN IF DAMAGES ARE CAUSED BY THE NEGLIGENCE OR FAULT OF BLIZZARD CORPORATION.

THE FOREGOING WARRANTIES ARE EXCLUSIVE AND IN LIEU OF ALL OTHER EXPRESSED AND IMPLIED WARRANTIES INCLUDING, BUT NOT LIMITED TO, THE IMPLIED WARRANTIES OF MERCHANTABILITY AND FITNESS FOR A PARTICULAR PURPOSE.

This warranty does not apply if you purchased your snowplow for personal, family, or household use.
In this case, refer to the Blizzard Snowplow Limited Consumer Warranty.



95 AIRPARK BOULEVARD ■ CALUMET, MICHIGAN 49913 ■ [906] 482-5555

810SS & 8611SS POWER PLOW™



95 Airpark Boulevard
Calumet, MI 49913
[888] 680-8600
[906] 482-5555
[906] 482-5445 Fax
www.blizzardplows.com

Blizzard, Power Plow, WidePass and BucketBlade are trademarks of Blizzard Corporation. Blizzard and Power Plow are registered in the United States Patent and Trademark Office. All other trademarks and registered trademarks are the property of their respective owners. All Blizzard snowplows are protected by one or more of the following United States Patents: 5,638,618; 5,899,007; 6,178,669; 6,276,076; and 6,393,737. Other patents pending. Copyright © 2005 Blizzard Corporation. All rights reserved. Made and printed in the USA. 64060